

# Cylinder station HP 260 Frontline

2x2 cylinder (bundle) single stage with manual changeover

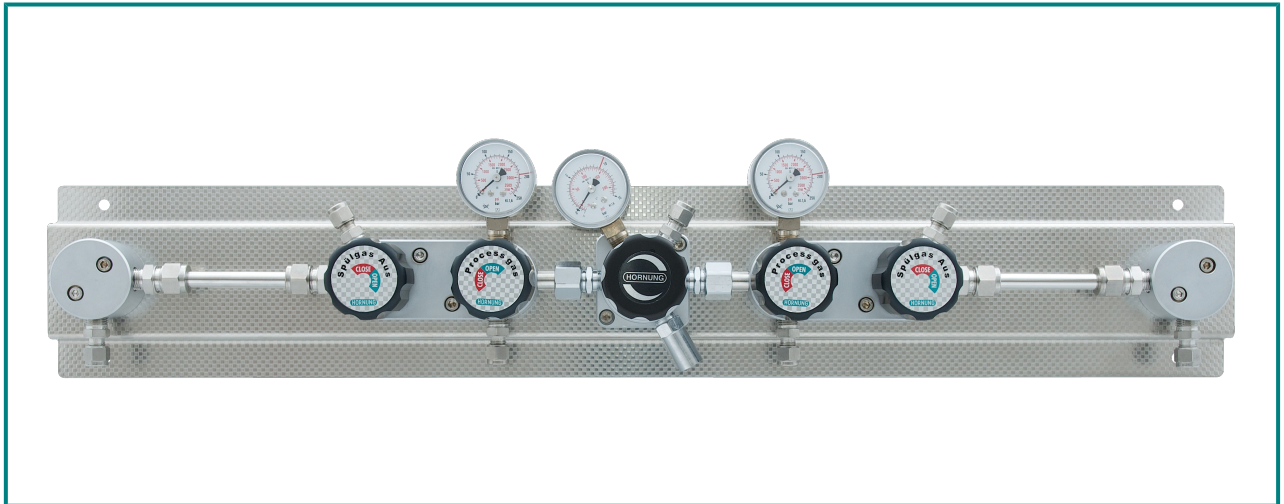

## Special characteristics:

Modular design of the pressure regulator and multifunction block.

Assembly and disassembly of all fixtures from the front.

Diaphragm shut-off valve in block design for Process and purge gas with open and close display.

Options for external gas purging can be retrofitted without any problem.

The HP 260 is a single stage panel for central gas supply with manual changeover and internal purging. It serves the safe supply of pure and mixed gases from 2x2 single or 2x2 bundled cylinders.

When changing cylinders, the gas supply must not be interrupted.

The station is mounted on a stainless steel console consisting of a pressure regulator with in and outlet pressure gauges as well as a relief valve and shut-off valve for the process gas and purge gas.

## Application area:

Especially for gases with high requirements on purity to 6.0. Secure and leak proof.

With options like contact gauges and gas alarm boxes (see segment 7) the supply concept can be optimised further.

Through our special cleaning system our pressure regulators are suitable for ECD – applications.

## Technical details:

Body: stainless steel 1.4404  
electro polished or  
brass, nickel and  
matt chrome plated

Seat: PCTFE

Diaphragm: 1.4435

Leakage rate:  $10^{-8}$  mbar l/s He  
Against atmosphere

Gas purity:  $\leq 6.0$

Max. inlet pressure: 300 bar

Outlet pressure ranges: 0,1–3; 0,1–6;  
1–12; 1–17 bar

Cv: 0,06

Operating temp.:  $-20^{\circ}\text{C}$  to  $+70^{\circ}\text{C}$

Gauges: safety version to:  
EN 837-1 KL1,6

Dimensions (WxHxD): 760x125x135

Weight: 7,6 kg

## Hornung Quality standard

The company Hornung is certified to

**DIN EN ISO 9001 and ISO 14001:2009.**

All single parts are manufactured, assembled and tested by in-house production.

The finished parts are therefore under all criteria of German quality control with 100% final inspection.

Hornung GmbH  
Rathenaustraße 55, 63263 Neu-Isenburg

Phone: +49 6102 7883-70

Fax: +49 6102 7883-40

[www.hornung.org](http://www.hornung.org)

[info@hornung.org](mailto:info@hornung.org)

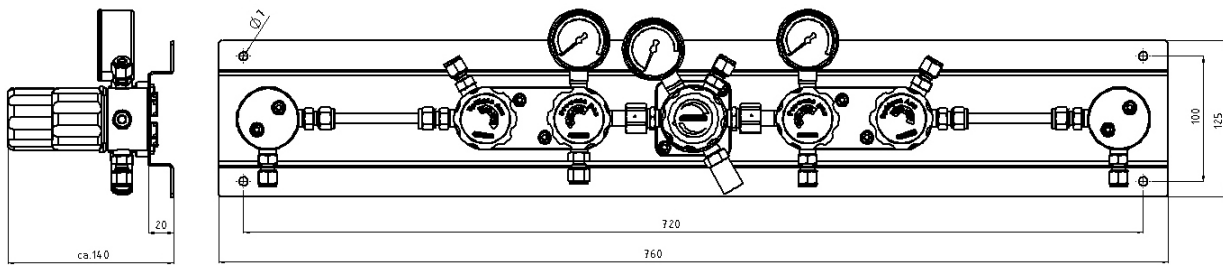

### Flow diagram:

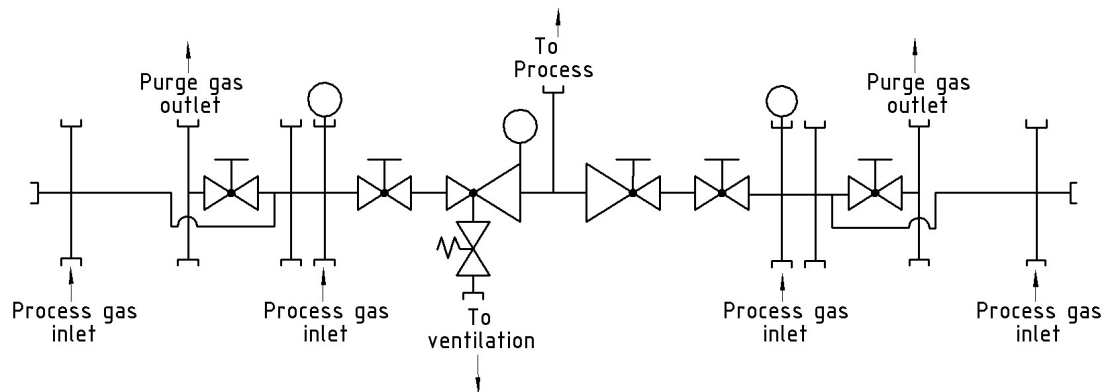

### Accessories:

#### See total catalogue segment

- 7. Pigtail 200bar
- Pigtail 300bar
- Connecting hose 200bar
- Connecting hose 300bar
- Gauges, compression fittings, cylinder holders and accessories.
- Gas cylinder cabinets und safety equipment.

#### Scope of supply:

Cylinder station with inlet and outlet gauge, Shut-off valve, Shut-off valve for process and purge gas.  
Completely mounted on a wall bracket out of stainless steel.

Without compression fittings.

### Ordering information:

#### Material:

- 1 = stainless steel
- 2 = brass

#### Inlet pressure p1:

- 1 = 200 bar
- 2 = 300 bar

#### Outlet pressure p2:

- 1 = 0,1 - 3 bar
- 2 = 0,1 - 6 bar
- 3 = 1 - 12 bar
- 4 = 1 - 17 bar

#### Gauges:

- 1 = standard gauge
- 2 = contact gauge ex

HP260-	2	1	4	3	Gas
Type	Mat.	p1	p2	Gauge	Gas type